

A/RE

FISH & RICHARDSON P.C.

225 Franklin Street
Boston, Massachusetts
02110-2804

Telephone
617 542-5070

Facsimile
617 542-8906

Web Site
www.fr.com

1c525 U.S. PTO
09/447228
11/22/99

11/22/99
1c490 U.S. PTO

Frederick P. Fish
1855-1930

W.K. Richardson
1859-1951

November 22, 1999

Attorney Docket No.: 0231/0314
00167/368001

BOX REISSUE APPLICATION
Assistant Commissioner for Patents
Washington, DC 20231

Presented for filing is a new original patent application of:

U.S. Patent No.: 5,690,676
Issued: November 25, 1997
Applicant: DiPoto et al.
Title: SUTURE ANCHOR AND DRIVE ASSEMBLY

This application is for a reissue of U.S. Patent No. 5,690,676, filed August 1, 1995, Serial No. 08/509,966, and issued November 25, 1997.

Enclosed are the following papers, including those required to receive a filing date under 37 CFR §1.53(b):

	<u>Pages</u>
Specification and claims	12
Abstract	1
Sheets of Drawing(s)	9
Certificate of Correction	1

"EXPRESS MAIL" Mailing Label Number EL2246709550S

Date of Deposit 11/22/99

I hereby certify under 37 CFR 1.10 that this correspondence is being deposited with the United States Postal Service as "Express Mail Post Office To Addressee" with sufficient postage on the date indicated above and is addressed to the Assistant Commissioner for Patents, Washington, D.C. 20231.

Samantha Bell
Samantha Bell

BOSTON
DELAWARE
NEW YORK
SILICON VALLEY
SOUTHERN CALIFORNIA
TWIN CITIES
WASHINGTON, DC

FISH & RICHARDSON P.C.

November 22, 1999

Enclosures:

Request for Transfer of Original Drawings	1
Preliminary Amendment	14
Information Disclosure Statement	1
PTO-1449, 2 pages	
References, 17 items	

Reissue filing fee	760.00
Reissue claims in excess of 20 times \$18.00	1,314.00
Reissue independent claims in excess of original patent times \$78.00	780.00
Total filing fee:	\$ 2,854.00

A check for the filing fee is enclosed. Please apply any other required fees or any credits to deposit account 06-1050, referencing the attorney docket number shown above.

If this application is found to be incomplete, or if a telephone conference would otherwise be helpful, please call the undersigned at 617/542-5070.

Kindly acknowledge receipt of this application by returning the enclosed postcard.

Please send all correspondence to:

Joel R. Petrow, Esq.
Chief Patent Counsel
Smith & Nephew North America
1450 Brooks Road
Memphis, TN 38116

Respectfully submitted,



Phyllis K. Kristal
Reg. No. 38,524
Enclosures

22. The anchor of claim 20 wherein said circumferential ridge includes a proximal surface orientated transversely to a longitudinal axis of the body.

23. The anchor of claim 22 wherein the proximal surface is perpendicular to the longitudinal axis of the body.

24. The anchor of claim 19 further including a plurality of non-helically arranged, exterior enlargements for engaging the bone upon insertion to resist withdrawal of said anchor from the bone.

25. The anchor of claim 24 wherein each of said plurality of exterior enlargements comprises a circumferential ridge.

26. The anchor of claim 25 wherein each circumferential ridge includes a distal, chamfered surface.

27. The anchor of claim 25 wherein each circumferential ridge includes a proximal surface orientated transversely to a longitudinal axis of the body.

28. The anchor of claim 27 wherein the proximal surface is perpendicular to the longitudinal axis of the body.

29. The anchor of claim 25 wherein said circumferential ridges have outer extents of about the same diameter.

30. The anchor of claim 25 wherein at least one circumferential ridge has an outer diameter which differs from an outer diameter of another of said circumferential ridges.

31. The anchor of claim 19 wherein said body has a rounded distal end.

32. The anchor of claim 19 wherein said body has a pointed distal end.

33. The anchor of claim 19 wherein said opening has open ends, said body having an outer surface defining a pair of suture receiving channels, each suture receiving channel being aligned with one of said open ends.

34. The anchor of claim 33 wherein said suture receiving channels extend to a proximal end of said body.

35. The anchor of claim 19 wherein said body has a cylindrical exterior surface.

36. An anchor for insertion into a bone hole to secure a suture to bone, comprising:

a body having a cylindrical exterior surface, said body defining an opening for receiving the suture, and

a non-helical circumferential ridge extending from the cylindrical exterior surface of said body for engaging the bone upon insertion to resist withdrawal of said anchor from the bone.

37. The anchor of claim 36 wherein said body is rigid.

38. The anchor of claim 36 wherein said opening extends generally transversely through said body.

39. The anchor of claim 36 wherein said circumferential ridge includes a distal, chamfered surface.

40. The anchor of claim 36 wherein said circumferential ridge includes a proximal surface orientated transversely to a longitudinal axis of the body.

41. The anchor of claim 40 wherein the proximal surface is perpendicular to the longitudinal axis of the body.

42. The anchor of claim 36 further including a plurality of circumferential ridges for engaging the bone upon insertion to resist withdrawal of said anchor from the bone.

43. The anchor of claim 42 wherein each circumferential ridge includes a distal, chamfered surface.

44. The anchor of claim 42 wherein each circumferential ridge includes a proximal surface orientated transversely to a longitudinal axis of the body.

45. The anchor of claim 44 wherein the proximal surface is perpendicular to the longitudinal axis of the body.

46. The anchor of claim 42 wherein said circumferential ridges have outer extents of about the same diameter.

47. The anchor of claim 42 wherein at least one circumferential ridge has an outer diameter which differs from an outer diameter of another of said circumferential ridges.

48. The anchor of claim 36 wherein said body has a rounded distal end.

49. The anchor of claim 36 wherein said body has a pointed distal end.

50. The anchor of claim 36 wherein said opening has open ends, said body having an outer surface defining a pair of suture receiving channels, each suture receiving channel being aligned with one of said open ends.

51. The anchor of claim 50 wherein said suture receiving channels extend to a proximal end of said body.

52. An anchor for insertion into a bone hole to secure a suture to bone, comprising:

a rigid body defining a generally transverse opening extending through said body for receiving the suture, said opening having open ends, said body having an outer surface defining a pair of suture receiving channels, each suture receiving channel being aligned with one of said open ends, said body including an engaging member configured to engage the bone upon insertion to resist withdrawal of said anchor from the bone.

53. The anchor of claim 52 wherein said suture receiving channels extend through said engaging member.

54. The anchor of claim 52 wherein said suture receiving channels extend to a proximal end of said body.

55. The anchor of claim 52 wherein said engaging member comprises a circumferential ridge.

56. The anchor of claim 55 wherein said circumferential ridge is non-helically arranged.

SECRET

57. The anchor of claim 55 wherein said circumferential ridge includes a distal, chamfered surface.

58. The anchor of claim 55 wherein said circumferential ridge includes a proximal surface orientated transversely to a longitudinal axis of the body.

59. The anchor of claim 58 wherein the proximal surface is perpendicular to the longitudinal axis of the body.

60. The anchor of claim 52 further including a plurality of engaging members for engaging the bone upon insertion to resist withdrawal of said anchor from the bone.

61. The anchor of claim 60 wherein each of said plurality of engaging members comprises a circumferential ridge.

62. The anchor of claim 61 wherein said plurality of circumferential ridges are non-helically arranged.

63. The anchor of claim 61 wherein each circumferential ridge includes a distal, chamfered surface.

64. The anchor of claim 61 wherein said circumferential ridge includes a proximal surface orientated transversely to a longitudinal axis of the body.

65. The anchor of claim 64 wherein the proximal surface is perpendicular to the longitudinal axis of the body.

66. The anchor of claim 61 wherein said circumferential ridges have outer extents of about the same diameter.

67. The anchor of claim 61 wherein at least one circumferential ridge has an outer diameter which differs from an outer diameter of another of said circumferential ridges.

68. The anchor of claim 52 wherein said body has a rounded distal end.

69. The anchor of claim 52 wherein said body has a pointed distal end.

70. The anchor of claim 52 wherein said body has a cylindrical exterior surface.

71. An anchor for insertion into a bone hole to secure a suture to bone, comprising:

a rigid body defining a generally transverse opening extending through said body for receiving the suture,

said body having an exterior enlargement configured to enable the anchor to be non-rotationally advanced into a bone

hole and to engage the bone upon insertion to resist withdrawal of said anchor from the bone.

72. The anchor of claim 71 wherein said enlargement comprises a non-helical circumferential ridge.

73. The anchor of claim 72 wherein said circumferential ridge including a distal, chamfered surface.

74. The anchor of claim 72 wherein said circumferential ridge includes a proximal surface orientated transversely to a longitudinal axis of the body.

75. The anchor of claim 74 wherein the proximal surface is perpendicular to the longitudinal axis of the body.

76. The anchor of claim 71 further including a plurality of non-helically arranged, exterior enlargements for engaging the bone upon insertion to resist withdrawal of said anchor from the bone.

77. The anchor of claim 76 wherein each of said plurality of exterior enlargements comprises a circumferential ridge.

78. The anchor of claim 77 wherein each circumferential ridge includes a distal, chamfered surface.

79. The anchor of claim 77 wherein each circumferential ridge includes a proximal surface orientated transversely to a longitudinal axis of the body.

80. The anchor of claim 79 wherein the proximal surface is perpendicular to the longitudinal axis of the body.

81. The anchor of claim 77 wherein said circumferential ridges have outer extents of about the same diameter.

82. The anchor of claim 77 wherein at least one circumferential ridge has an outer diameter which differs from an outer diameter of another of said circumferential ridges.

83. The anchor of claim 71 wherein said body has a rounded distal end.

84. The anchor of claim 71 wherein said body has a pointed distal end.

85. The anchor of claim 71 wherein said opening has open ends, said body having an outer surface defining a pair of suture receiving channels, each suture receiving channel being aligned with one of said open ends.

86. The anchor of claim 85 wherein said suture receiving channels extend to a proximal end of said body.

87. The anchor of claim 71 wherein said body has a cylindrical exterior surface.

88. An anchor assembly, comprising:
an anchor body defining an opening for receiving a first portion of suture, and
a drive tool for inserting said anchor body in bone, said drive tool including a mount for releasably receiving a second portion of the suture to enable said anchor body to be secured to said drive tool at least in part by attaching the second portion of the suture to the mount.

89. A method of securing a suture to a bone, comprising:
providing an anchor including a rigid body defining a generally transverse opening extending through said body for receiving the suture, said body having a non-helically extending exterior enlargement,
threading suture through the generally transverse opening, and
inserting the anchor within a bone hole such that said enlargement engages the bone to resist withdrawal of said anchor from the bone hole.

60227 "SECRET"

90. A method of securing a suture to a bone, comprising:

providing an anchor including a body having a cylindrical exterior surface, said body defining an opening for receiving the suture, and a non-helical circumferential ridge extending from the cylindrical exterior surface of said body,

threading suture through the opening, and

inserting the anchor within a bone hole such that said circumferential ridge engages the bone to resist withdrawal of said anchor from the bone hole.

91. A method of securing a suture to a bone, comprising:

providing an anchor including a rigid body defining a generally transverse opening extending through said body for receiving the suture, said opening having open ends, said body having an outer surface defining a pair of suture receiving channels, each suture receiving channel being aligned with one of said open ends, said body including an engaging member configured to engage the bone upon insertion to resist withdrawal of said anchor from the bone,

threading suture through the generally transverse opening,

placing a first length of suture in a first of said pair of suture receiving channels, and a second length of suture in a second of said pair of suture receiving channels, and

inserting the anchor within a bone hole such that said engaging member engages the bone to resist withdrawal of said anchor from the bone hole.

92. A method of securing a suture to a bone, comprising:

providing a rigid body defining a generally transverse opening extending through said body for receiving the suture, said body having an exterior enlargement configured to enable the anchor to be non-rotationally advanced into a bone hole and to engage the bone upon insertion to resist withdrawal of said anchor from the bone,

threading suture through the opening, and

inserting the anchor within a bone hole by applying only an axial force, said circumferential ridge engaging the bone to resist withdrawal of said anchor from the bone hole.

93. A method of attaching an anchor body to a drive tool, comprising:

attaching a first portion of a suture to said anchor body,

attaching a second portion of the suture said drive tool such that said anchor body is secured to said drive tool at least in part by attaching the second portion of the suture to the drive tool.

REMARKS

Applicants submit that no new matter has been introduced, and request entry of new claims 19-93.

Applicants submit that all of the claims are in condition for allowance, which action is requested.

Please apply any charges or credits to Deposit Account No. 06-1050.

Respectfully submitted,

Date: November 22, 1999

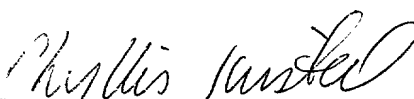

Phyllis K. Kristal
Reg. No. 38,524

Fish & Richardson P.C.
225 Franklin Street
Boston, MA 02110-2804

Telephone: 617/542-5070
Facsimile: 617/542-8906
375782.B11

66227 "SECRET"



US005690676A

United States Patent [19]

[11] Patent Number: 5,690,676

DiPoto et al.

[45] Date of Patent: Nov. 25, 1997

[54] SUTURE ANCHOR AND DRIVE ASSEMBLY

[75] Inventors: Gene Philip DiPoto, Cumberland, R.I.; Jeffrey C. Cerier, Franklin, Mass.; Russell F. Warren, Greenwich, Conn.; Gerard S. Carlozzi, Weymouth; Paul DiCarlo, E. Falmouth, both of Mass.; James W. Dwyer, Brookfield, Conn.; Alan Attridge Small, Needham, Mass.

[73] Assignee: Smith & Nephew, Inc., Andover, Mass.

[21] Appl. No.: 599,966

[22] Filed: Aug. 1, 1995

Related U.S. Application Data

[60] Continuation of Ser. No. 91,092, Jul. 12, 1993, abandoned, which is a division of Ser. No. 836,679, Feb. 14, 1992, Pat. No. 5,258,016, which is a continuation-in-part of Ser. No. 681,042, Apr. 5, 1991, abandoned, which is a continuation-in-part of Ser. No. 552,440, Jul. 13, 1990, Pat. No. 5,100,417.

[51] Int. Cl.⁶ A61B 17/04
[52] U.S. Cl. 606/232; 606/72; 606/73
[58] Field of Search 606/65, 73, 86, 606/104, 139, 170, 220, 232

[56] References Cited

U.S. PATENT DOCUMENTS

2,329,398	9/1943	Duffy	606/104
3,845,772	11/1974	Smith	606/104
4,409,974	10/1983	Freedland	128/92
4,454,875	6/1984	Pratt et al.	
4,496,468	1/1985	Li	606/232
4,532,926	8/1985	O'Holla	606/139
4,632,100	12/1986	Somers et al.	606/73
4,653,486	3/1987	Coker	128/92
4,669,473	6/1987	Richards et al.	
4,738,255	4/1988	Goble et al.	606/86

4,776,328	10/1988	Frey et al.	128/92
4,895,148	1/1990	Bays et al.	606/213
4,968,315	11/1990	Gattuma	606/72
5,002,550	3/1991	Li	606/139
5,037,422	8/1991	Hayhurst et al.	606/72

FOREIGN PATENT DOCUMENTS

0260970	3/1988	European Pat. Off.	
2606270	5/1988	France	
WO89/01767	3/1989	WIPO	
WO89/10096	11/1989	WIPO	

OTHER PUBLICATIONS

Arthrex Brochure—"Arthrex ESP System: Expanding Suture Plug"—Feb., 1991? [Published prior to Mar. 1, 1991].

Primary Examiner—Michael Buiz
Assistant Examiner—Daphna Shai
Attorney, Agent, or Firm—Fish & Richardson P.C.

[57] ABSTRACT

A suture anchor and anchor driver device for securely and accurately positioning and installing the suture anchor in place. The anchor has a rounded or pointed head and one or more ridges around it to help force fit the anchor into a hole and to hold it in place. A suture is positioned through the anchor for subsequent use during the surgical procedure. The driver device has a handle and an elongated shaft and is used to position and install the anchor in place. The anchor preferably snap fits onto the end of the shaft. A depth guide can be integrally or removably positioned on the shaft to ensure correct depth of placement. Alternately, the driver shaft is hollow and the anchor is positioned inside it and is implanted with a pusher member. The ends of the suture are affixed to the driver handle. Grooves can be provided on the driver and the anchor to prevent the suture from interfering with the positioning and installation procedure.

18 Claims, 9 Drawing Sheets

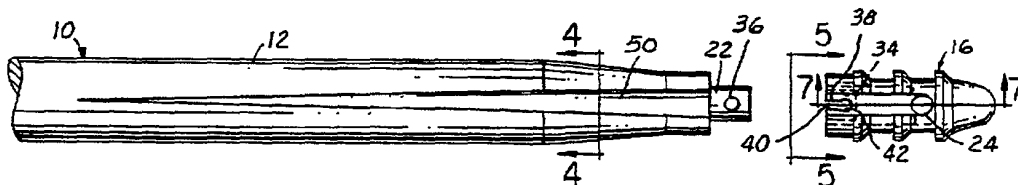

SECRET

SUTURE ANCHOR AND DRIVE ASSEMBLY**CROSS REFERENCES**

This is a continuation of application Ser. No. 08/091,092, 5
 filed Jul. 12, 1993, now abandoned, which is a divisional of
 application Ser. No. 07/836,679, filed Feb. 14, 1992, now
 U.S. Pat. No. 5,258, 016 which is a continuation-in-part of
 application Ser. No. 07/681,042, filed Apr. 5, 1991, now
 abandoned, which is a continuation-in-part of application 10
 Ser. No. 07/552,440, filed Jul. 13, 1990, issued as U.S. Pat.
 No. 5,100,417.

FIELD OF THE INVENTION

A suture anchor for implanting in bone or tissue for 15
 surgical use is disclosed. The anchor is releasably engagable
 with the end of a driver device for reliable positioning and
 installation during surgery.

BACKGROUND OF THE INVENTION 20

Anchoring or affixation devices and systems for medical
 or surgical applications are in common use today. The
 anchors are implanted to aid in holding bone, tissue, liga-
 ments and the like together or in place until healing takes 25
 place, or are used temporarily to help perform a procedure
 necessary for optimum surgical results. When implanted
 permanently, the anchors can be made from an absorbable
 material if desired.

Bone and suture anchors are used, for example, during
 orthopedic surgery to hold fractured bones together, to affix 30
 ligaments to bones and to aid in determining isometric
 placement of anterior cruciate ligament replacements.
 Examples of such anchors are shown in U.S. Pat. Nos.
 4,537,185, 4,632,100, 4,640,271, 4,723,541 and 4,738,255. 35

Some positioning and driver mechanisms and systems are
 known which are used to accurately position and install bone
 anchors in place. Examples of such mechanisms and sys-
 tems are disclosed, for example, in U.S. Pat. Nos. 3,990,438,
 4,537,185, 4,632,100, 4,723,541 and 4,738,255. Two other 40
 known systems are the "Statak" mechanism marketed by
 Zimmer, Inc., Warsaw, Ind. and the "Isotac" mechanism
 marketed by Acufex Microsurgical, Inc., Mansfield, Mass.

SUMMARY OF THE INVENTION 45

It is an object of the present invention to provide an
 improved suture anchor for surgical use. It is another object
 of the present invention to provide an improved driver
 device for a suture anchor.

Yet another object of the present invention is to provide a 50
 suture anchor which readily and reliably attaches and
 detaches from a driver.

A further object of the present invention is to provide such
 a suture anchor which carries a simple yet strong attachment 55
 element for engaging the driver.

A further object of the invention is to provide such a
 suture anchor which maintains a desired alignment with the
 driver during insertion.

It is a still further object of the invention to provide a 60
 surgical anchor and driver assembly which allows efficient
 and accurate positioning and placement of the suture anchor
 during surgery, the anchor being able to be affixed either for
 permanent or temporary use, and the driver being able to
 remove the installed anchor if desired. 65

It is also an object of the invention to provide an anchor
 and driver assembly in which the suture anchor can be

temporarily securely affixed to the driver device for installation and removal, and be removed easily from the driver device when desired. It is another object to provide means on the driver device to hold the anchor temporarily in place and prevent it from rotating relative to the driver device.

It is still another object to provide a surgical suture anchor and driver assembly in which a suture can be used to hold the anchor in place, the suture being recessed or positioned in a way not to obstruct or cause a problem during positioning, installation and/or removal of the anchor.

Another object of the invention is to provide a guide member for determining and limiting the depth of insertion of the anchor in the bone.

These and other objects are met by the present invention which will become apparent upon review of the following detailed description of the invention, when taken by itself or in view of the drawings.

The present invention relates to a unique and improved anchor, an anchor driver device, and a combined anchor and driver assembly. The anchor is a suture anchor with a rounded, conical or pointed tip which assists installation of the anchor into a previously drilled hole in bone or tissue. One or more ridges around its circumference act to hold the anchor in position in the hole for its intended use. Preferably, a suture is positioned through a hole in the anchor and extends from the anchor for subsequent use by the surgeon to hold ligaments, bones or tissue in place, or for use during isometric testing of the positioning for a substitute anterior cruciate ligament, for example.

The anchor is adapted to be securely positioned on the end of a driver device. The driver has a handle and elongated shaft. The anchor snaps or force fits onto the end of the shaft and is keyed against rotation. A guide member, which can be integral with the shaft, can be used to ensure correct depth of placement of the anchor and protect the sutures during use. The suture is affixed to the handle of the driver and grooves or slots may be provided along the driver shaft for positioning of the sutures during use of the anchor and driver assembly. By positioning the sutures in the grooves, they are placed out of the way so they cannot interfere with positioning, placement, installation or removal of the anchor.

In an alternative embodiment, the anchor is hollow and the driver handle and shaft are cannulated. This allows the sutures to be passed through the anchor and driver and not interfere with the installation or removal procedures. In yet another embodiment, the anchor and driver cannulated to receiving a guide wire.

In another alternate embodiment, the driver device is also hollow and the anchor members are sized to fit inside of it. A pusher member is used to push the anchor member out of the driver and insert it into the bone or bone-like structure.

BRIEF DESCRIPTION OF DRAWINGS

FIG. 1 illustrates a unique anchor and driver assembly with the anchor being positioned and held in place on the driver;

FIG. 2 is a partial exploded view of the anchor and the end of the driver illustrating their features and showing how they are affixed together;

FIG. 3 is a partial exploded view similar to FIG. 2 but with the anchor and driver shaft rotated 90° relative to the view shown in FIG. 2 and with the suture removed for ease of viewing;

FIG. 4 is a cross-sectional view of the driver shaft taken along lines 4—4 in FIG. 3;

FIG. 5 is an end plan view of the anchor viewed along lines 5—5 in FIG. 3;

FIG. 6 is an end plan view of the driver device viewed along lines 6—6 in FIG. 1;

FIG. 7 is a cross-sectional view of the anchor taken along lines 7—7 in FIG. 3;

FIGS. 8 and 9 illustrate alternate embodiments of a hollow anchor and driver device;

FIGS. 10, 10A and 11 illustrate the use of the inventive anchor and driver assembly with a separate depth guide member to install an anchor into a hole drilled in bone;

FIG. 12 illustrates the "setting" of the anchor in the drilled hole;

FIG. 13 illustrates the use of the invention to affix soft tissue to the bone;

FIG. 14 illustrates another alternate embodiment of the invention;

FIG. 15 depicts still another embodiment of a solid, rod-type anchor;

FIGS. 16A and 16B are proximal end views of alternative embodiments of anchors according to the present invention in which the anchors define intact sockets for engaging a driver;

FIG. 17 is a longitudinal cross-sectional view along lines 17—17 of FIG. 16A and FIG. 18 is similar cross-sectional view along lines 18—18;

FIGS. 19 and 20 are different side views of a driver for engaging the anchors shown in FIGS. 16A, 17 and 18;

FIGS. 21A and 21B are end and cross-sectional views, respectively, of yet another anchor according to the present invention having a tapered drive socket;

FIGS. 22A and 22B are partial side views of the distal ends of the drivers for engaging the anchor shown in FIG. 21;

FIG. 23 is a similar side view showing a driver having an integral depth stop and an engagement tip which facilitates an interference or force-fit with the suture anchor;

FIG. 24 is a cross-sectional view of yet another anchor and driver in which the anchor projects into a socket in the driver;

FIGS. 25 and 26 are cross-sectional views of other anchors having tapered and stepped ridges, respectively;

FIG. 27 is a perspective view of a cannulated anchor according to the present invention and a method for its installation;

FIGS. 28 and 29 are end and side elevational views of the cannulated anchor;

FIG. 30 depicts use of the cannulated anchor after it is installed; and

FIG. 31 depicts an alternate embodiment of a cannulated anchor.

DETAILED DESCRIPTION OF INVENTION

The features and details of one embodiment of a unique anchor and driver assembly are shown in FIGS. 1-7. The driver device is generally designated by the reference numeral 10 and the anchor by the reference numeral 16.

The driver device has a shaft member 12 attached or connected to a handle member 14. The shaft member and handle member can be separate members securely fastened together or they can be made from a single piece of material. Preferably the handle is a hollow stainless tube member having the shape shown in FIGS. 1 and 6 and the shaft is a

stainless steel rod which is soldered, welded or otherwise affixed in or to the handle.

The anchor 16 is situated for installation (and also for removal if that is desired) on end projection 22, FIGS. 2 and 3, of the shaft 12, in a manner to be described in more detail below. A suture 18 is positioned through a hole or opening 24 in the anchor 16 and the two ends 26 and 28 of the suture are securely wrapped or tied around fixation posts 30 and 32, respectively, FIG. 1. In order to securely hold the sutures which are wrapped on the posts 30 and 32, O-rings preferably are positioned on the stems of each of the posts. (O-rings 33 are shown in FIG. 10.)

The positioning of the anchor 16 on end 22 and the affixation of the suture 18 on the fixation posts 30, 32 tightly and securely holds the anchor on the driver for use during surgery. In this manner, the anchor will not be subject to being dislodged, moved out of position on the shaft or accidentally displaced from the shaft while the driver is being used to position and place the anchor during surgery. This is particularly important when the anchor is being used during arthroscopic knee, shoulder or other joint surgery and it would be harmful for the anchor to become loose in the joint.

The end projection 22 is adapted to fit within a mating recess or socket 34 in the anchor 16, as shown in FIGS. 2, 3 and 5. The cross-sectional size and shape of the projection 22 and socket 34 can be of any common geometric shape, but preferably have the same shape and are circular, as shown by FIG. 5. If desired, the outside diameter of projection 22 and the inside diameter of socket 34 also can be dimensioned such that the two members have a frictional or slight force fit relationship.

A dowel or pin 36 is positioned in end projection 22 substantially perpendicular to the longitudinal axis of the driver device. The pin 36 projects on both sides of the end 22 forming two "ears" or "tabs".

The rod-type anchor 16 has a pair of slots 38 which are formed on opposite sides (180° apart) of the end of the anchor which fits on the driver device. The slots 38 are positioned and dimensioned to snap over and onto the protruding ends of the pin 36 on the driver. The slots 38 have an elongated passageway 40 which is slightly smaller in width than the cross-sectional diameter of the pin 36 and a larger generally circular end portion 42 which has substantially the same diameter as the pin 36.

The pin 36 "keys" the anchor to the shaft and driver so that the anchor cannot be rotated relative to the driver; the pin insures that the anchor can be rotated and maneuvered only with the driver.

The dimensioning of the slots 38 relative to the pin 36 also creates a force fit mating relationship and assembly between the anchor and driver device. The anchor 16 has to be forced onto the end 22 of the shaft by forcing the two ends of the pin 36 through the passageways 40 and into the openings 42. The anchor is resilient and "snaps" into place with the openings 42 on the shaft 36. This frictional or force-fit relationship also helps insure that the anchor and driver device will remain together during positioning and installation of the anchor during surgery.

The anchor in one construction made from a polyacetal such as Delrin 150SA material, but it can be made of any other equivalent or compatible plastic or surgical material. It is also possible for some applications for the anchor to be made of a bio-absorbable material, such as polyglycolic acid (PGA) or polylactic acid (PLA). U.S. Pat. Nos. 3,739,773 (Schmitt et al.), 4,300,565 (Rosensaft et al.) and 4,429,080

(Casey et al.) are incorporated herein by reference for their disclosure of bioabsorbable material.

One suture to be utilized with the present invention is No. USP Size 2 Ticron material made by Davis & Geck Co. It is understood, of course, that any other equivalent suture or other material can be used so long as it satisfies the purposes and objects of the present invention.

The suture 18 can be placed through the hole in the anchor 16 before or after the anchor is positioned on the end of the driver shaft.

A pair of elongated slots or grooves 50, FIGS. 3 and 4, are provided on the shaft 12. The grooves are positioned 180° apart on the shaft and are of sufficient size and depth to position and retain the suture 18. The grooves 50 are oriented on the driver in axial alignment with the protruding ends of the pin 36 and with the fixation posts 30 and 32. When the anchor 16 is positioned on the driver 10, the suture 18 is tightly pulled into the grooves 50, down the length of the shaft 12 and securely wrapped and affixed around the posts 30 and 32. The ends 26 and 28 of the suture 18 are wound tightly around the fixation posts 30 and 32 which helps to hold the anchor on the driver during use.

After the anchor is positioned and installed in place, the ends of the suture are released from the posts 30 and 32 and the driver is pulled from the site. The fixation of the anchor 16 in the bone or tissue must be sufficiently strong and secure to allow the post 36 to be removed from the slots 38. Once the driver device is removed, the anchor 16 and suture 18 attached thereto are positioned in place for subsequent use during surgery. One such use is to fasten the end of a substitute or synthetic ACL ligament. In general, the anchor can be utilized to attach or reattach soft tissue, ligaments and tendons to bone. In these applications, the anchor would remain permanently in place. Another such use is the isometric testing of a proposed position for installation of an ACL replacement. In this application, the anchor and suture would be removed (and discarded) after the isometric testing was completed. In order to remove the anchor 16, the driver device is again utilized and the installation process reversed.

The shape and configuration of the anchor 16 is best shown in FIGS. 2, 3, 5 and 7. The anchor has a front end or tip 60 which is rounded, conical or pointed for ease of placement and insertion. A sharp pointed anchor would allow it to pierce soft tissue more easily. A plurality of circular ridges 62 extend around the circumference of the anchor and are used to firmly and securely hold the anchor 16 in place in a hole.

When the hole for the anchor 16 is drilled or formed in the bone or tissue, the diameter of the drill should be slightly less than the outer diameter of the ridges 62. In this manner, the anchor 16 can be forced into position in the hole and the compression and friction caused by the ridges 62 against the inner walls of the hole will hold it firmly in place.

Preferably the outer diameter of the ridges is 0.169 inches and the length of the anchor is 0.410 inches. The socket 34 has a diameter of 0.078 inches and a depth of 0.100 inches. The diameter of the end projection 22 is preferably 0.076-0.077 inches and the length of the pin 36 is 0.097 inches. The passageway of the slots 38 has a width of 0.025 inches and the pin 36 has a diameter of 0.0313 inches. The overall length of the driver device 10 (handle and shaft) is approximately 10 inches. Other sizes and dimensions for the present invention can also be utilized.

Three ridges 62 are shown on the anchor 16 and utilized in the preferred embodiment for sufficient strength of the anchor and to provide the requisite holding force in the bone

or tissue. It is understood, of course, that a greater or lesser number of ridges could be provided in accordance with the present invention so long as the objects and purposes of the present invention are obtained.

5 After the hole in the bone or tissue is formed (by drilling, for example with a K-wire having a diameter of 0.146 inches), the anchor 16 is "snapped" into position on the end 22 of the shaft of the driver and the suture 18 tightly wound on the fixation posts. The anchor and driver assembly is then
10 maneuvered or moved into position by the surgeon (e.g. arthroscopically), and the tip 60 of the anchor positioned at or in the opening of the hole. The anchor 16 is then forced axially into the hole by, for example, the surgeon tapping on the end of the driver with a mallet or the like. It is not
15 necessary to rotate the assembly in order to install it in position.

In an alternate embodiment, a driver device 80, FIGS. 8 and 9, having a handle 82 and shaft 84, is cannulated and the suture 18 is passed down the length of the driver and affixed on a fixation post 86 positioned adjacent the end 88 of the
20 handle 82. The suture 18 is passed through opening 90 in a hollow anchor 92 and out through the open hollow interior 94 of the anchor 92. In this embodiment, a suture passer can be utilized to thread the suture through the passageway or channel 96 in the driver 80. The driver 80 and an attached
25 anchor can be guided over a guide wire when the anchor defines a guide wire passage as described below for FIGS. 27-31.

To avoid over-penetration of the anchor 16 into the bone, a guide member 70 is positioned over the shaft 12 of the
30 driver instrument in one construction, as shown in FIG. 10. The guide member is a hollow cylindrical member, preferably made of plastic, and slips over the driver and anchor assembly after the anchor is positioned on the driver device
35 and the ends of the suture 18 are attached to the fixation posts 30 and 32. Preferably, the guide member 70 is held in place on the driver instrument 10 by a stop or collar member 64 which is soldered to the shaft 12 (see FIG. 10A). The guide member 70 has a pair of opposed slots 66 which
40 snap-fit over pins 68 on the stop member in order to hold it in place. The guide member also protects the sutures during use of the assembly during surgery. A series of guide members of different lengths can be provided in order to provide the insertion depth desired by the surgeon for the
45 anchor. When the anchor is installed in the bone or bone-like structure 72, as shown in FIG. 11, the end 74 of the guide member 70 contacts the bone and prevents the anchor from being inserted too far into the bone.

Once the anchor is firmly set in place, the ends 26 and 28
50 of the suture 18 are removed (unwound) from the fixation posts 30 and 32 and the driver is removed from the surgical site. Since the anchor is retained in the hole with a greater force than that required to snap and unsnap the anchor from the pin 36 on the driver, the driver can be removed easily
55 from the anchor by the surgeon. The two ends of the suture 18 preferably are pulled firmly at an angle to the bone 72, FIG. 12, to ensure a firm fit and more securely set the anchor in place. The anchor with suture attached is then used for its intended use. One such use is shown in FIG. 13 where the
60 suture 18 is tied through a soft tissue (ligament) 76 securely fastening it to the bone 72. In this manner, the ligament is mechanically reattached to the bone and, over time, the two members grow together and become permanently biologically reattached.

65 If the anchor is to be removed after use, or moved to another position, the installation process is repeated in reverse order, as mentioned earlier.

In another embodiment, FIG. 14, the driver device 100 is hollow with a central opening 102 through the length of the elongated shaft 104 and handle 106. The anchor member 110 is sized sufficiently small to fit within the opening 102 and has a suture 112 attached to it, in the same manner as suture 18 is attached to anchor 16 as described above. A pusher member 114 consisting of an elongated tubular member 116 and head or handle 118 is inserted in the opening 102 and used to drive the anchor member 110 through and out of the driver device 100 and into the bone or bone-like structure. The suture 112 is threaded through the driver device and pusher member, as shown.

In order to gauge and measure the depth of insertion of the anchor member 110, markings or a scale 120 can be provided on the pusher member. The "hollow tube" driver device is particularly useful for insertion of small anchor member 110, such as on the order of about one-sixteenth of an inch in diameter and three-sixteenths of an inch in length.

A solid anchor 130, FIG. 15, has a rod-shaped body 132 with a pair of annular rings 134 and 136 on its outer surface. The front end 138 of the anchor is flat with a 45° chamfer around the edge in order to ease entry of the anchor into the hole in the bone. Chamfer or angled surfaces 140 and 142 are provided on the leading edges of the rings 134 and 136 also in order to ease entry of the anchor into the bone. A hole 144 with opposed slots 146 and 148 are provided for positioning of the suture.

Additional embodiments of suture anchors and drivers according to the present invention are shown in FIGS. 16A-26 in which the anchor has greater strength and structural integrity at the region of engagement with the driver. Anchor 150, FIGS. 16A, 17 and 18, includes an elongated body 152, a drive socket 154, first and second discontinuous, interrupted ridges 156, 158, and continuous, uninterrupted distal ridge 160. The anchor 150 further includes a rounded distal tip 162, and a suture passage 164. A pair of grooves 166, 168 are disposed on opposing sides of the anchor 150. The inner, proximal portions of the grooves 166, 168 are bounded by flat surfaces 170, 172.

A substantial wall thickness is thereby achieved for walls 173, 175 which lie between the grooved surfaces 170, 172 and the flat surfaces 174, 176 of the socket 154. The thickness and configuration of walls 173 and 175 provide increased resistance to initiation and propagation of fractures as compared with anchor 16, FIGS. 5-7.

By comparison, the grooves 166a, 168a of alternative anchor 150a, FIG. 16B, have rounded surfaces 170a, 172a which provide a deeper channel in which a thicker suture can be nested. To maintain the same dimensions of the socket 154a as for socket 154, FIG. 16A, the walls 153a, 155a are thinner. When the anchor is to be constructed of a bioabsorbable material and is to be relatively small in size, the construction shown in FIG. 16A enables a stronger angled force to be applied to the anchor 150. The greater strength can be especially desired in surgical applications where anchor insertion cannot occur exactly perpendicular to the bone surface.

A gradual transition is made between the grooves 166, 168 and the transverse passage 164 by shoulders 180, 182 as shown in FIG. 17. Forces applied on a loaded suture, such as for suture 18 in FIGS. 12 and 13, are thereby distributed fairly uniformly over the areas of contact between the suture and the anchor.

The distal portion of a driver 184, FIGS. 19 and 20, terminates in a drive element 186 which closely matches shape of the socket 154 of anchor 150. A shoulder 188 is

formed proximally on the shaft 185 to engage the proximal end of the anchor 150. The shaft 185 further includes an integral depth stop 190 that is larger in diameter than the hole drilled in the bone and therefore acts as a depth guide to limit insertion of the anchor 150. The shaft 185 further defines a trough or slot 192 which increases in width and depth as it extends distally to the shoulder 188. A portion of the suture lies in slot 192 when the anchor 150 is secured to the driver 184 similar to the manner shown in FIG. 1, above.

Preferred dimensions for one construction of the anchor 150 and the driver 184 are as follows. The anchor 150 has an overall length of 0.41 inch and a maximum diameter of 0.148 inch at proximal region 177. The ridges 156, 158, 160 have a greater diameter of 0.169 inch. The socket 154 has a length of 0.15 inch, a minimum width of 0.064 inch and a maximum width of 0.078 inch. The socket 154 is therefore narrower in a first dimension as shown in FIG. 17 than along a second dimension as shown FIG. 18.

In this construction, the socket walls 173, 175 have a width of 0.023 inch and the passage 164, FIG. 18, has a minimum diameter of 0.056 inch. The grooves 166, 168 have a width of 0.055 inch and a depth of 0.029 inch. The distal region 179 has a maximum diameter of 0.128 which successively narrows progressing distally.

The driver 185, FIGS. 19 and 20, is 9.85 inch in length, and the shaft 185 has a diameter of 0.187 inch. The shoulder 188 has a diameter of 0.14 inch while the drive engagement element 186 has a width along the dimension shown in FIG. 19 of 0.077 inch and a width along the dimension shown in FIG. 20 of 0.067 inch. The latter width is slightly larger than the corresponding width of the socket 154 which generates a friction or force-fit between the anchor 150 and the driver 185 to snugly attach the anchor to the driver. The non-circular cross-sections of the socket 154 and the driver element 186 ensure accurate alignment between the anchor grooves 166, 168 and the shaft slots 192 so that a suture can be nestled therein to avoid impingement with the bone or other tissue. The slot 192 has a maximum width of 0.053 inch and a depth of 0.028 inch at shoulder 188 in this construction, and exhibits a slope of approximately two degrees.

Anchor 200, FIGS. 21A and 21B, is similar to anchor 150 but defines a socket 202 which becomes narrower progressing distally to provide greater overall strength for the anchor 200 by allowing thicker distal walls. The socket 202 progresses from proximal dimensions of 0.078 inch by 0.064 inch distally to cross-sectional dimensions of 0.050 inch by 0.040 inch. The distal taper of the socket 202 also enables deeper suture grooves 201, 203 without compromising the strength and integrity of the anchor 200.

The anchor 200 further includes projections 204, 206 which engage matching recesses 205, 207, FIG. 22A, of a driver engagement element 208. Driver shoulder 210 engages the proximal end of the driver 200 for insertion of the anchor as described above. The interlocking of the matching detents and recesses provide resistance to separation between the anchor and the driver in an alternative manner to the force-fit interlocking between driver element 186 and socket 154 described above.

Alternatively, projections 205a, 207a are located on the driver element 208a as shown FIG. 22B. Matching recesses are defined in the corresponding anchor.

Two additional driver-to-anchor engagement arrangements are shown in FIGS. 23 and 24. A driver 212 includes an integral depth stop 214, a driver shoulder 216, and a drive element 218 having a proximal straight section 220 and a

distal tapered section 222. The straight section 220 enables an interlocking force-fit with corresponding anchor while the distal tapered section 222 enables the more distal portions of the anchor to be thicker and therefore stronger.

A driver 224, FIG. 24, defines a distal socket 226 for engaging a projection 228 of an anchor 230. A distal surface 232 of the driver 224 serves as an engagement shoulder for transferring force to the proximal end of the anchor 230. In one construction, the depth stop 234 has a diameter of 0.185 inch, the shoulder 232 has an outer diameter of 0.14 inch and socket 226 has a diameter ranging from 0.06 to 0.1 inch.

While most of the anchors described above have rounded, bullet-shaped distal tips, this is not a limitation of the invention. Other tip configurations include frustoconical geometries and other shapes preferably having a successively narrowing cross-section proceeding distally to facilitate insertion into a previously drilled hole.

Additional variations within the scope of the present invention include two or more ridges of different diameters as shown in FIGS. 25 and 26. Anchor 240 includes a proximal ridge 242 having a diameter of 0.169 inch, an intermediate ridge 244 having a diameter of 0.157 inch, and a distal ridge 246 having a maximum diameter of 0.145 inch. Each ridge defines an inclined leading surface 248 and an outer bone engagement surface 250. In this construction, the surfaces 250 of the ridges 242, 244 and 246 are tapered at an angle A of up to ten degrees, more preferably at five to seven degrees.

Preferably, the resulting outer diameter of the distal ridge 246 is the same or slightly greater than the diameter of a hole drilled in bone into which the anchor 240 is to be inserted. The successively decreasing diameters of the ridges in the distal direction decreases the insertion force required to implant the anchors while retaining high-pull out resistance, especially as provided by the more proximal, greater-diameter ridges. Additionally, the proximal region 252 can have the same or slightly greater diameter than the drilled hole to enhance frictional engagement with the bone hole.

Decreasing diameter as provided by stepped ridges is shown for anchor 260 in FIG. 26. Ridges 262, 264, 266 have outer, bone engaging surfaces 263, 265, 267 which are parallel to the longitudinal axis 268 but are of decreasing, stepped diameter progressing distally. In one construction, the intermediate ridge 264 has a radial difference B of 0.006 inch relative to the proximal ridge 262 and the distal ridge 266 has a radial difference C of 0.012 inch to facilitate insertion into the bone. In addition to providing an increased surface area for engagement with bone, the non-triangular profile of the ridges provides increased strength and minimizes shear of the ridges.

A suture anchor in accordance with the present invention can also be cannulated as indicated generally by the reference numeral 310 in FIGS. 27-30. The anchor 310 has a generally cylindrical body 312 with a pointed leading end 314. The end 314 can be rounded, conical or pointed and is angled to assist the entrance and positioning of the anchor in a bone hole. Preferably, the leading end 314 is shaped to "blend" into the guide wire when it projects through the anchor 310.

The body 312 has a plurality of ridges 316 on its outer surface. The ridges help affix the anchor in position in a hole 318 in a bone 320. The ridges are sized slightly larger than the diameter of the hole to provide an interference or force-fit relationship. It is understood that the ridges can have a conventional shape and can consist of barbs or other structures provided for the same locking purpose.

Prior to the present invention involving an offset guide wire channel, it was not possible to install small suture anchors over guide wires or positioning mechanisms. There was insufficient room in the anchor body for both a cannulated passageway required for installation purposes as well as the channel and slots needed to attach the suture to the anchor.

An alternate embodiment of a cannulated anchor according to the invention is shown in FIG. 31. A traverse suture passageway 332' of an anchor 310' is positioned offset from the direct intersection with the central longitudinal axis 334' while the longitudinal passageway 350' for the guide wire extends along the central axis. In this manner, the guide wire 352' and suture 330' also do not interfere with one another during installation of the anchor 310' because passageway 332' and 350' do not intersect.

Although particular embodiments of the present invention have been illustrated in the accompanying drawings and described in the foregoing detailed description, it is to be understood that the present invention is not to be limited to just the embodiments disclosed, but that they are capable of numerous rearrangements, modifications and substitutions without departing from the scope of the claims hereafter.

What is claimed is:

1. An anchor for securing a suture to bone, comprising:
 - an elongated body having a proximal region terminating in a proximal end, and a distal region terminating in a distal end configured for insertion into a hole in the bone;
 - said proximal region including an element configured for positive axial interengagement with a corresponding element of a driver for insertion of said anchor into the hole, said element of said proximal region including one of a protrusion or a recess which axially interlocks with a corresponding recess or protrusion, respectively, of the corresponding driver element;
 - at least one ridge, disposed on an exterior surface of said body, for engaging the bone after insertion to resist withdrawal of said anchor; and
 - a suture mount carried by said elongated body.
2. The anchor of claim 1 wherein said recess includes an opening in said proximal region of said anchor or in said driver.
3. The anchor of claim 1 in which said element of said anchor includes a projection extending from said elongated body for engaging a matching socket of the corresponding driver element.
4. The anchor of claim 1 in which said element of said anchor is narrower in cross-section along a first dimension than along another cross-sectional dimension.
5. The anchor of claim 1 in which said element of said anchor includes a socket defined by said elongated body which has an opening communicating with said proximal end of said body, and said socket is narrower in cross-section along a first dimension than along another cross-sectional dimension.
6. The anchor of claim 5 in which said socket also becomes smaller in width in said first dimension progressing distally to a distal base of said socket.
7. The anchor of claim 1 in which said elongated body further defines a passageway for receiving a guide wire during insertion of said anchor.
8. The anchor of claim 7 in which said suture mount includes a hole in said elongated body, and said passageway does not intersect said hole.

663317 "BEE" 4460

9. The anchor of claim 1 wherein said element of said proximal region of said anchor is configured to provide a snap fit with the corresponding element of the driver.

5 10. The anchor of claim 9 wherein said element of said proximal region of said anchor is further configured so that the snap fit is sufficiently strong to allow said anchor to be removed from the bone hole after insertion.

10 11. The anchor of claim 1 wherein said element of said proximal region of said anchor comprises a projection on said elongated body and the element of the driver includes a recess that receives said projection to provide the positive axial interengagement.

15 12. The anchor of claim 1 wherein said element of said proximal region of said anchor comprises a recess on said elongated body and the element of the driver includes a projection which is received in the recess to provide the positive axial interengagement.

20 13. An anchor and driver assembly comprising:
 an anchor member including an elongated body having a proximal region terminating in a proximal end, and a distal region terminating in a distal end configured for insertion into a hole in a bone;
 25 a driver member having a handle member and a shaft member, said shaft member having a drive element at its distal end;
 said proximal region of said anchor member including an element configured for positive axial interengagement
 30 with said drive element for insertion of said anchor into the hole by said driver member, said element of said anchor member including one of a protrusion or a recess which axially interlocks with a corresponding recess or protrusion, respectively, of said drive element;
 35 at least one ridge, disposed on an exterior surface of said body, for engaging the bone after insertion to resist withdrawal of said anchor member; and
 a suture mount carried by said elongated body.

40 14. The assembly of claim 13 wherein said driver member has a passageway therethrough, and said anchor member has an opening therein communicable with said passageway and with said suture mount.

45 15. The assembly of claim 13 further comprising a suture member attached to said anchor member by said suture mount, passing through said opening, and being positioned in said passageway.

50 16. The anchor of claim 13 in which said anchor member and said driver member each define a passageway alignable with each other to receive a guide wire through both said passageways to assist placement during insertion of said anchor member.

55 17. The assembly of claim 13 wherein said driver element includes a pin arranged transversely to a longitudinal axis of said shaft member, and said element of said anchor member includes a socket in said elongated body for receiving said pin.

60 18. The assembly of claim 17 wherein said socket includes a slot having an open proximal end and a closed distal end, said closed distal end being substantially the same size as said pin and said slot being narrower than said pin, thereby to provide the positive axial interengagement with said pin.

65

SECRET

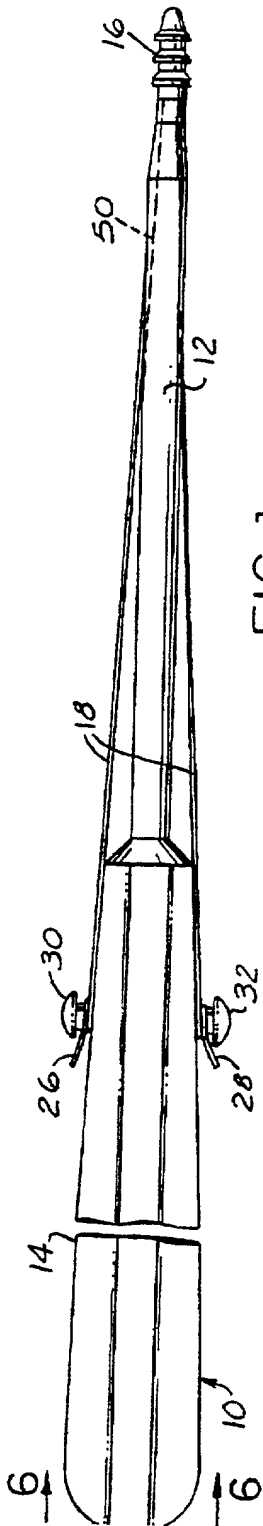

FIG. 1

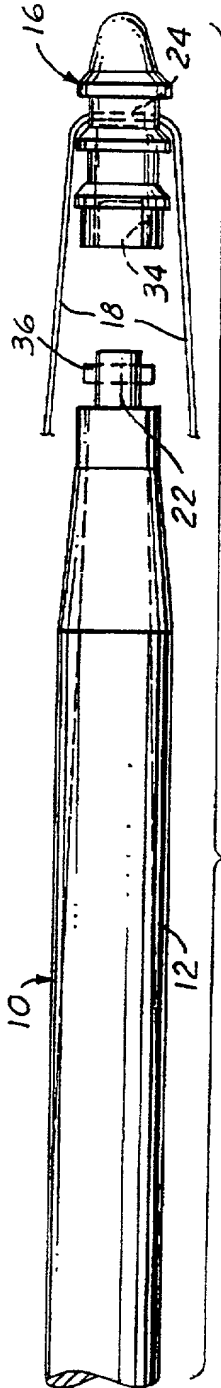

FIG. 2

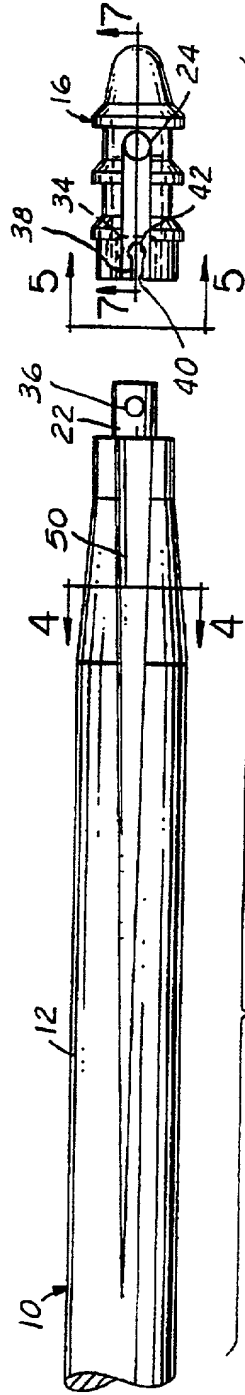

FIG. 3

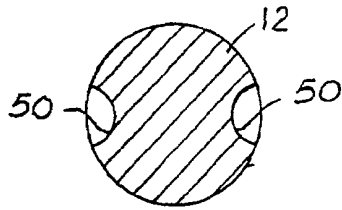

FIG. 4

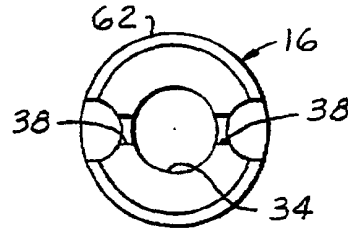

FIG. 5

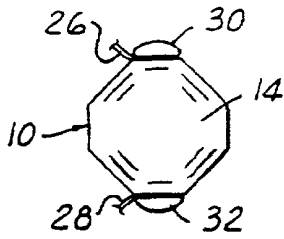

FIG. 6

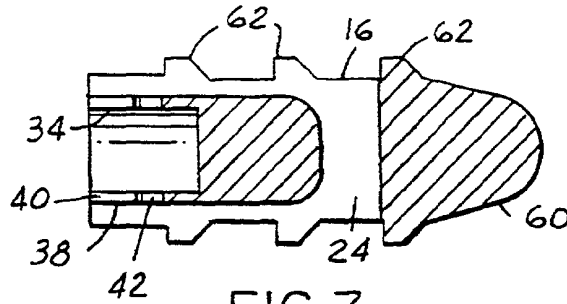

FIG. 7

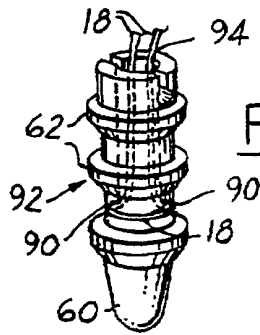

FIG. 8

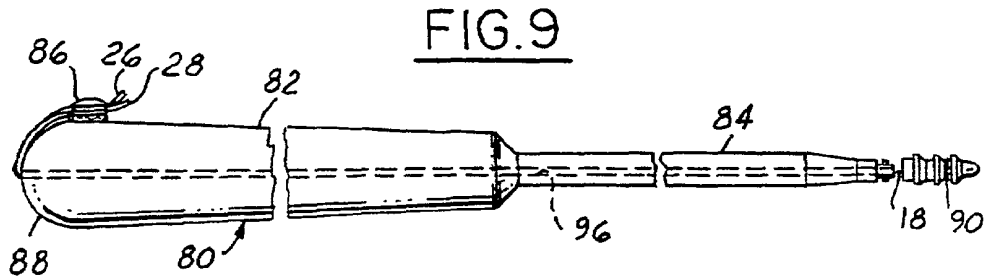
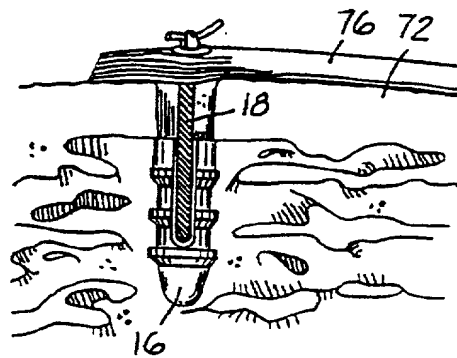
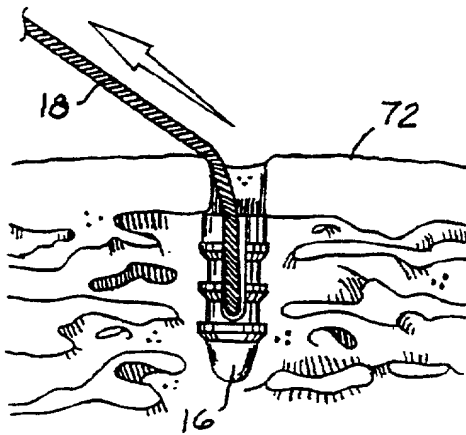
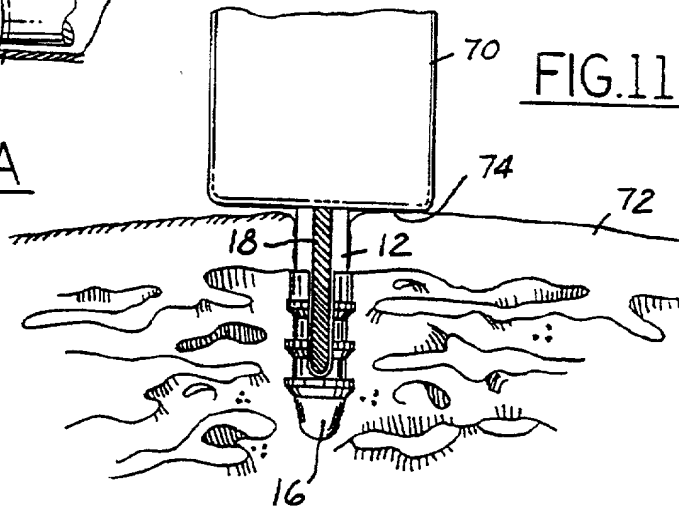
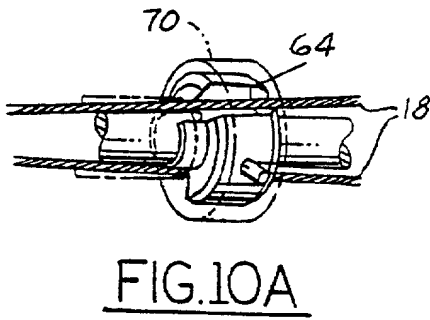
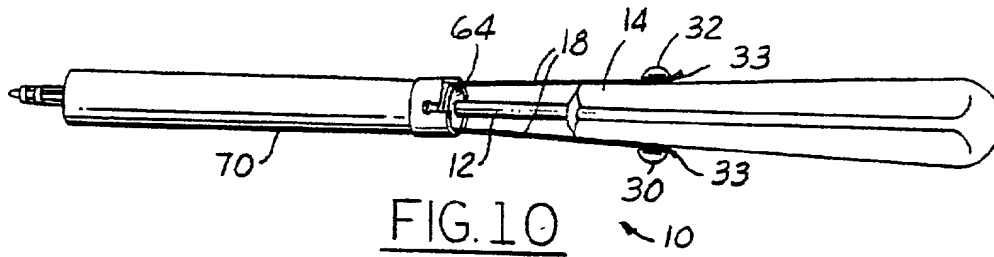

FIG. 9

66227" 8224460



SECRET 8224460

SECRET

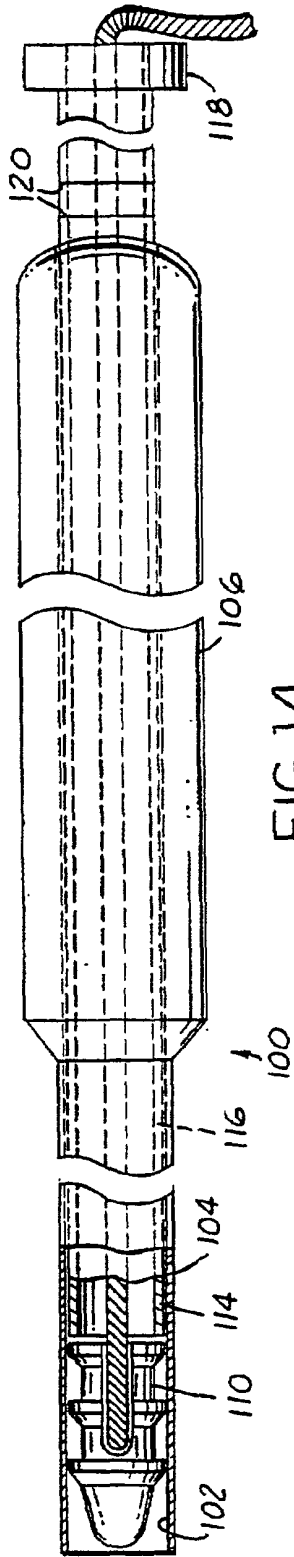

FIG. 14

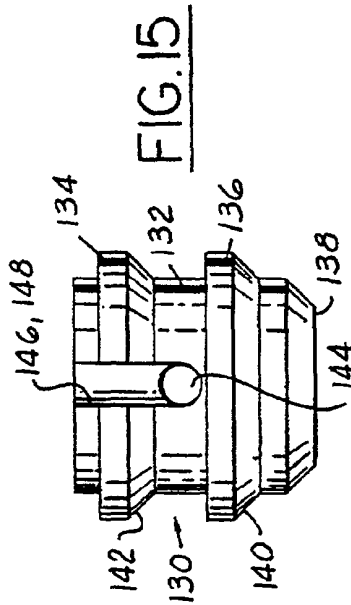

FIG. 15

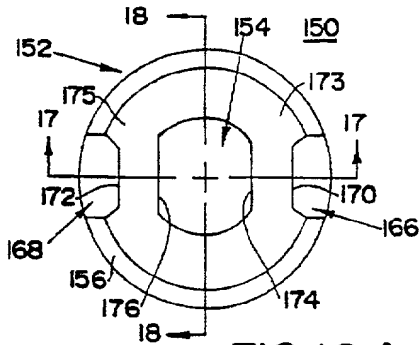

FIG. 16 A

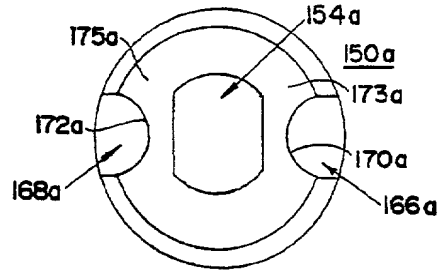

FIG. 16 B

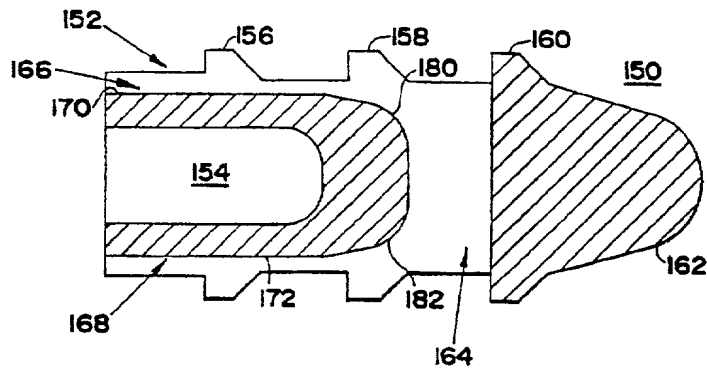

FIG. 17

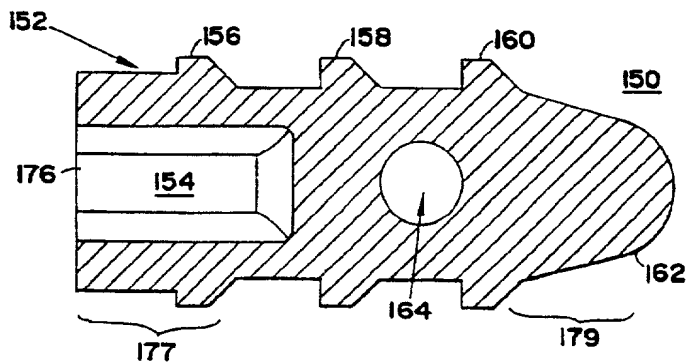

FIG. 18

66247" 824460

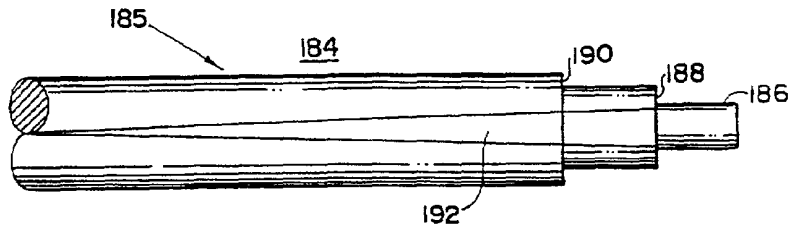

FIG. 19

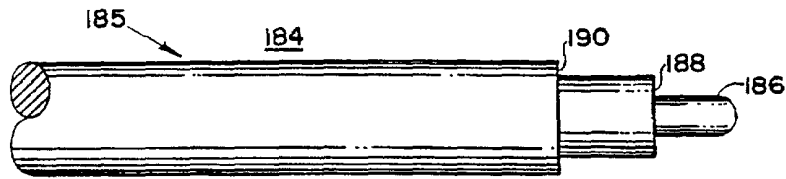

FIG. 20

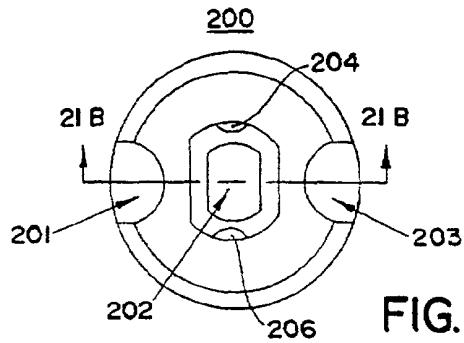

FIG. 21 A

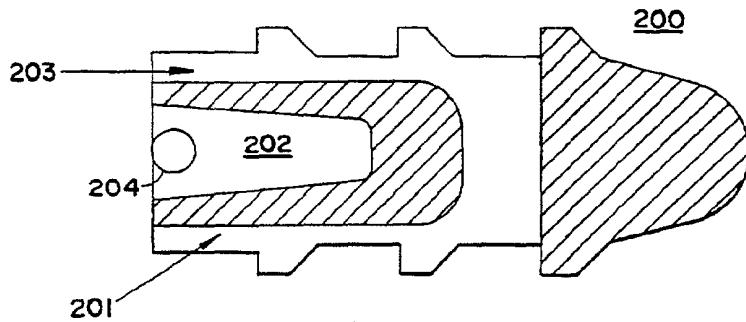

FIG. 21 B

SECRET 8224460

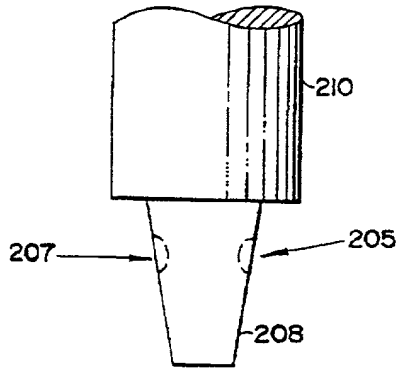

FIG. 22 A

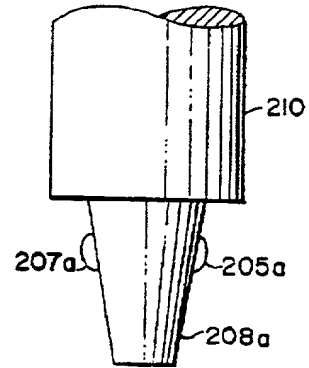

FIG. 22 B

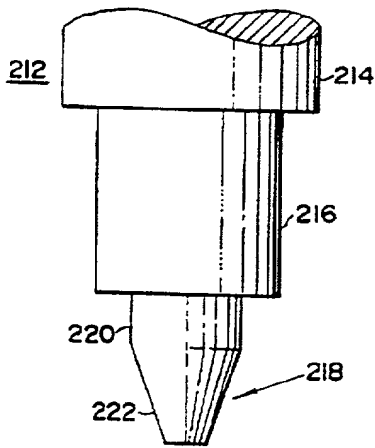

FIG. 23

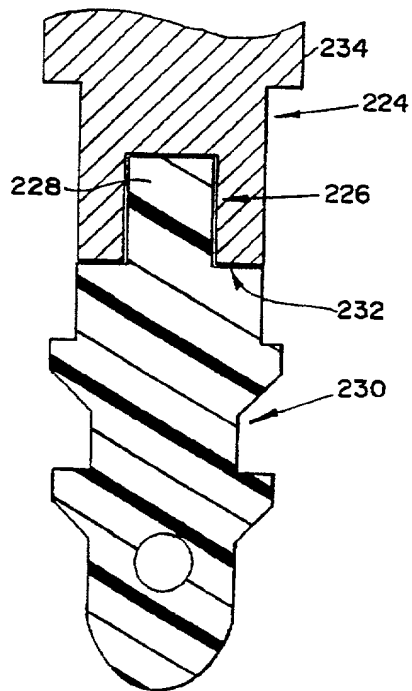
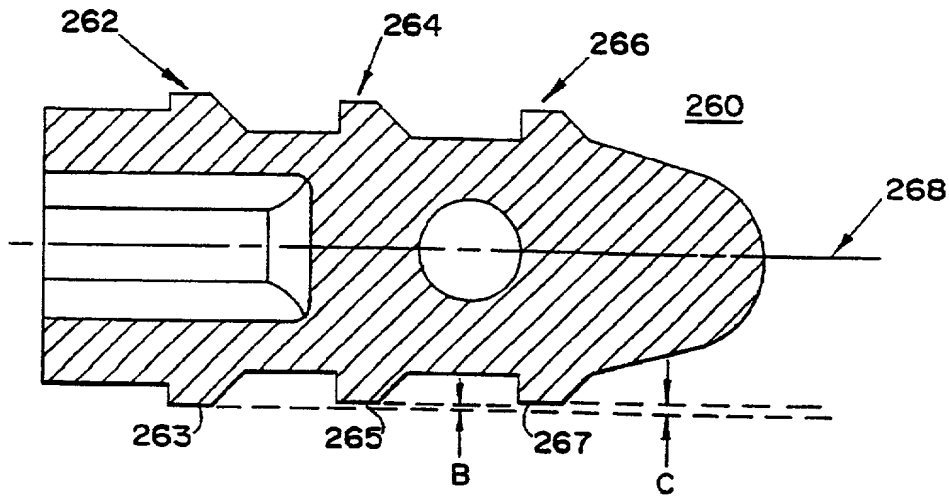
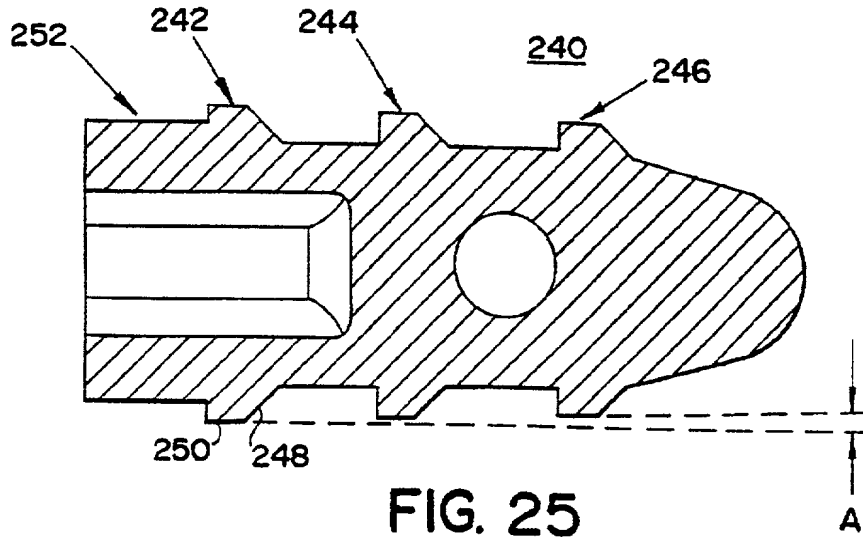

FIG. 24

66227-3-97



66227" 8224460

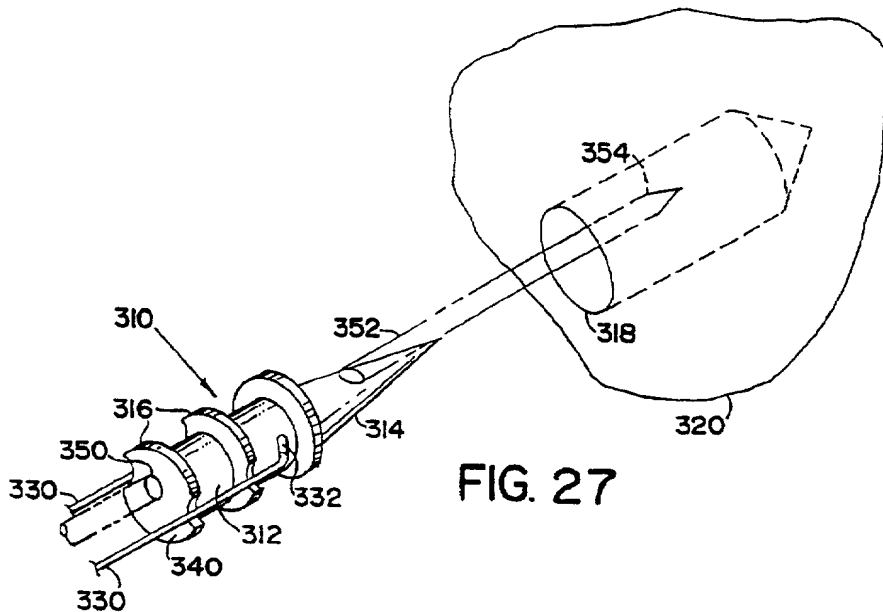

FIG. 27

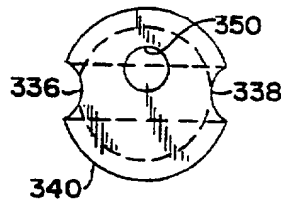

FIG. 28

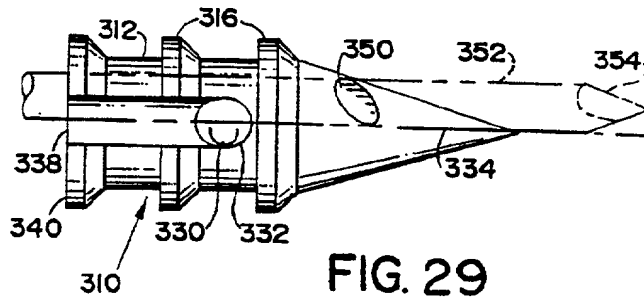

FIG. 29

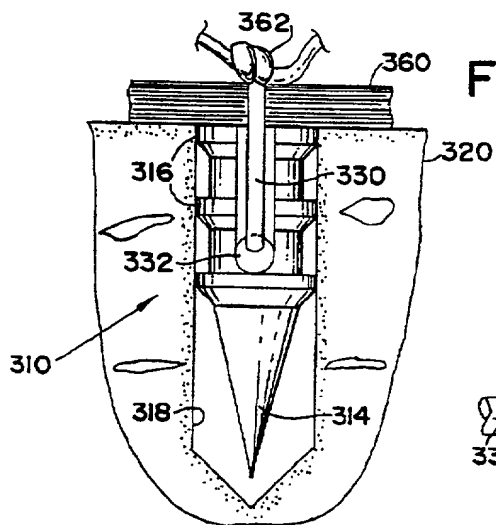

FIG. 30

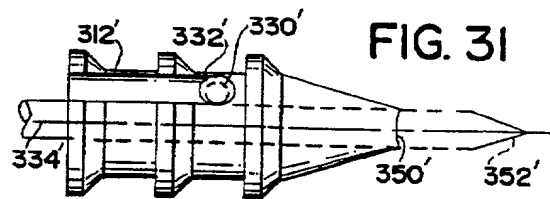

FIG. 31

66227 3224460